



SMART PADDLE™

Capacitive Sensors
Series 70 - NPN - Series 80 - PNP

Housing G1/2"

- Housing material: LCP
- SIP / CIP 121° C
- Special version with flange. Sealing can be made with a gasket or PTFE-tape (not supplied with the sensor)



Technical data	Non-flush mountable
Level sensor, in contact with the product	Medium dependent adjustable
Empfindlichkeit	Typ. ϵ_r 2...80
Electrical version	4-wire DC
Output function	Antivalent
Type PNP	KAS-80-P50-A-K-G1/2"-LCP-ETW
Art.-No.	KA 1323
Operating voltage (U_B)	10...35 V DC
Operating current	2 x 0...200 mA
Voltage drop max. (U_o)	≤ 2.0 V
Permitted residual ripple max.	10 %
No-load current (I_o)	Typ. 15 mA
Frequency of operating cycles max.	2 Hz
Permitted ambient temperature	-25...+70 °C / CIP 121° C (zero-current)
LED-display	Green / yellow
Protective circuit	Built-in
Degree of protection IEC 60529	IP 67
Norm	EN 60947-5-2
Connection cable	2 m, PVC, 5 x 0.34 mm ²
Housing material	LCP (FDA 21 CFR 176.170(c))
Active surface	LCP (FDA 21 CFR 176.170(c))
Lid	PA
Media optimized	Yes
Accessory: Varivent Adapter, Welding Socket (Please see our range of accessories, not supplied with the sensor).	

This capacitive level sensor is pre-adjusted for the detection of bulk materials or liquids with a dielectric constant ϵ_r of 2 to 80.

This fully electronic Paddle Sensor has no moving parts and is not subject to wear or tear and thus there is no down time due to false detections caused by material build-up.

Advantages SMART PADDLE:

- Sensitivity is pre-adjusted
- Measurement is independent of the mounting position
- Permitted pressure on the active area: 10 bar
- Process connection G 1/2"

All specifications are subject to change without notice. (08.09.2020)

EasyTeach chart: LED / Output function
Yellow = A1 Green = A2

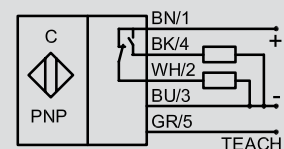
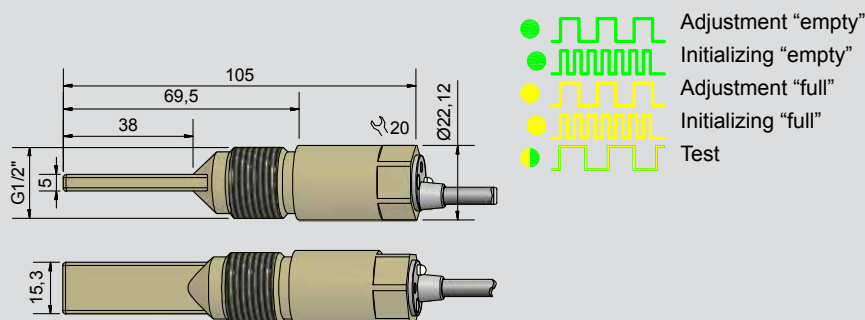

Made in Germany

Level Measurement in a New Dimension:

SMART TM PADDLE

The fully electronic paddle sensor.

This capacitive level sensor is designed for the level control of bulk materials and liquids with a dielectric constant (DC) of ϵ_r 2 to 80. It is media optimised and pre-adjusted, so that it can cover this large DC spectrum. An adjustment for the product to be detected simply is not necessary.



It cannot be easier.

The user mounts the sensor, makes the electrical connection and the sensor is ready for use.

The **SMART PADDLE** has no moving parts and is therefore not subject to wear or tear. It is ideal for applications where traditionally Rotary Switches, Vibrating Forks or Mechanical Switches are being used.

The advantages are obvious: easy installation, reliable level control and at the same time solving the well-known issues of mechanical systems being used today. No more down time due to false detections caused by material build-up, getting stuck between vibrating forks or around rotary switches, etc.

A variant with Easy Teach by Wire is an option for products where the dielectric constant is outside of the pre-set range.

The sensor's housing material, LCP, is very robust and also suitable for contact with food products.

The sensor has a G 1/2 inch process connection which can be used with a large range of accessories like welding brackets or „Varivent N DN 50“ flanges that are offered by Rechner.

Rechner sensors is your specialist for level control!

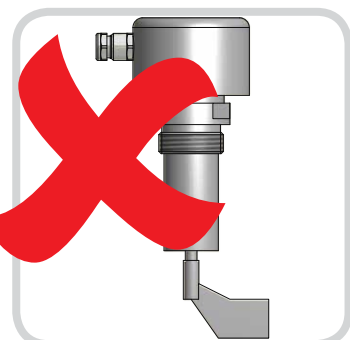
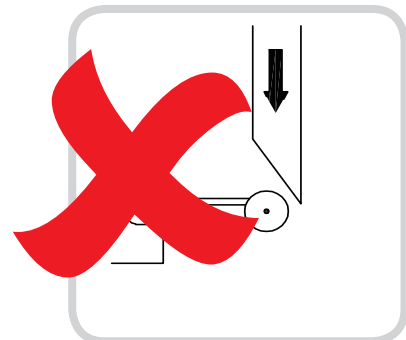
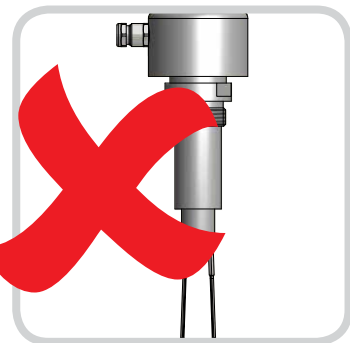

Made in Germany

All specifications are subject to change without notice. (08.09.2020)